

MODEL RCRX051A

EXPLOSION PROOF REFRIGERATOR

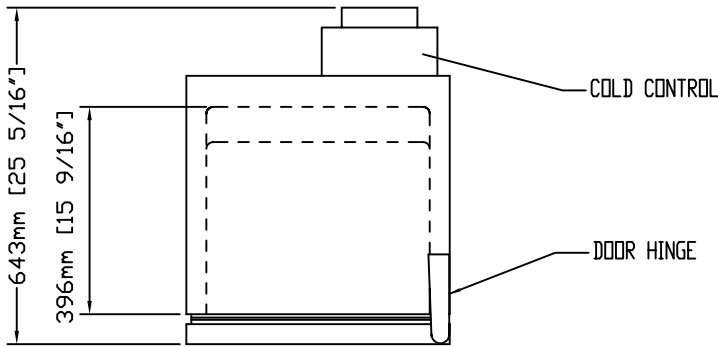

TOP VIEW

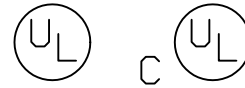
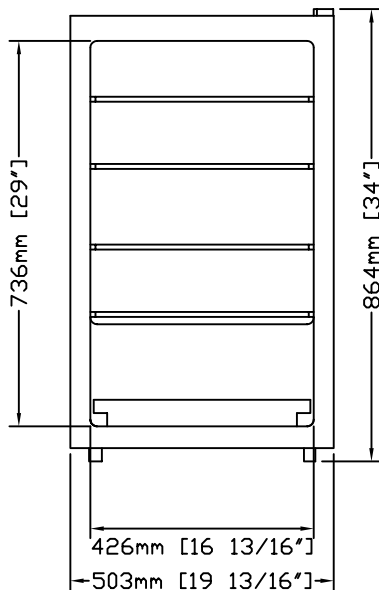

FRONT VIEW

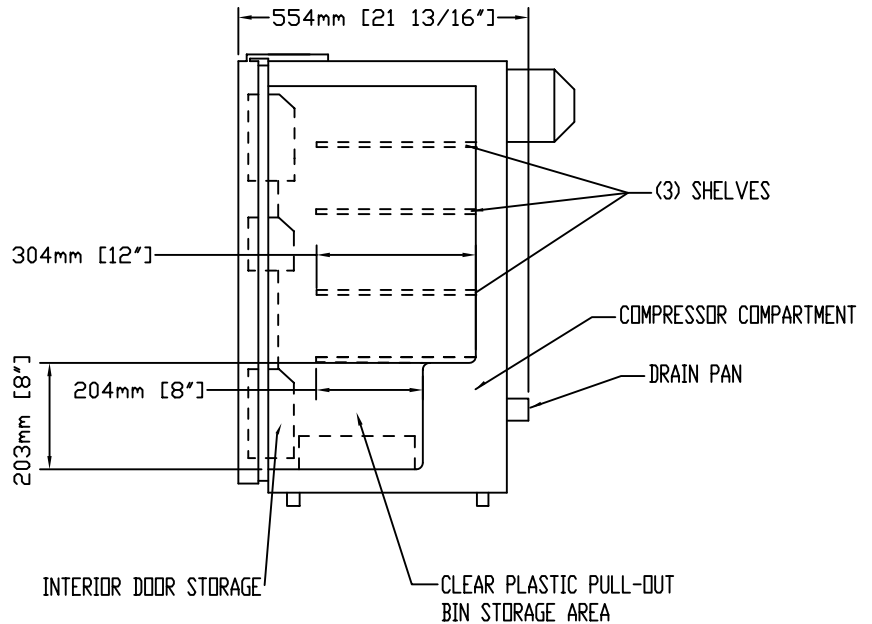

SIDE VIEW

11/2003

REVCO

REVCO
 275 Aiken Road
 Asheville, NC 28804
 TEL. 1-800-252-7100
 TEL. 828-658-2711 FAX 828-658-0363

MODEL RCRX051A

GENERAL SPECIFICATIONS

EXTERIOR - WHITE TEXTURED VINYL ON STEEL

WIDTH 503mm (19.8") DEPTH 643mm (25.3") HEIGHT 864mm (34")

INTERIOR - SEAMLESS LINER OF VACUUM-FORMED ABS PLASTIC, WHITE

WIDTH 427mm (16.8") DEPTH 396mm (15.6") HEIGHT 736mm (29")

INSULATION - FOAMED-IN-PLACE POLYURETHANE

GASKET - MAGNETIC

DOOR - SOLID, KEY LOCK

SHELVES - (4) EPOXY, REMOVABLE, (3) ADJUSTABLE IN 51mm (2")

INCREMENTS, (3) BUILT-IN DOOR SHELVES

FEET - (4) LEVELING, FRONT ONLY

CONTROL - (1) THERMOSTATIC, MAY BE SET FOR DESIRED TEMPERATURE

+2°C TO +10°C (36°F TO 50°F), FACTORY SET TO +4°C (39°F)

DEFROST - MANUAL

COMPRESSOR - 1/20 H.P., R134a REFRIGERANT, NOMINAL BTU'S TO ROOM

AMBIENT - 60 WATTS (204 BTU'S/HR)

DECIBEL RATING - 35 dBA

UL/CUL LISTED TO CLASS I, GROUPS C AND D

CAPACITY - 119 L (4.2 CU. FT.)

ELECTRICAL DATA - 120/60/1 1.8 AMPS, MUST BE HARDWIRED BY CUSTOMER

SHIPPING WEIGHT - 37 KG (82 LBS)

SHIPPING VOLUME - 0.5 CU. METERS (19 CU. FEET)