

MODEL RFS214A

FLAMMABLE STORAGE REFRIGERATOR

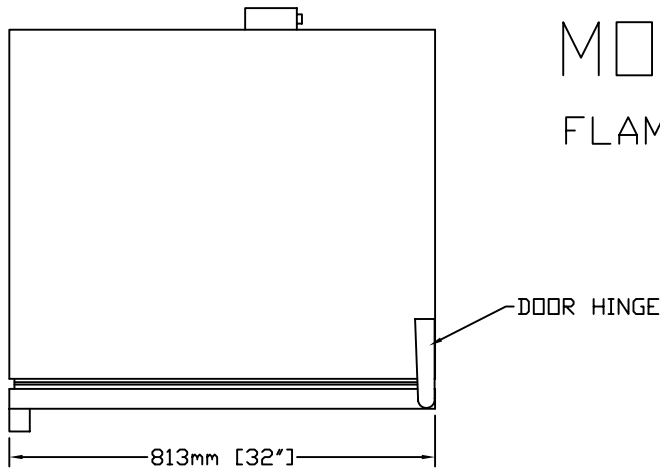

TOP VIEW

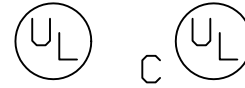
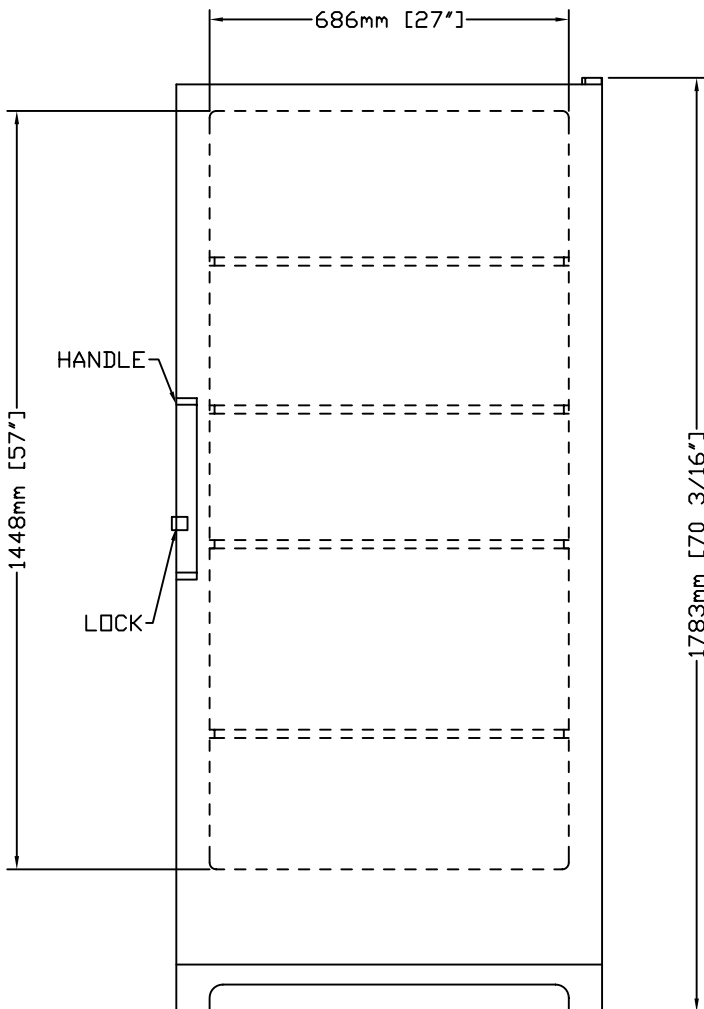

FRONT VIEW

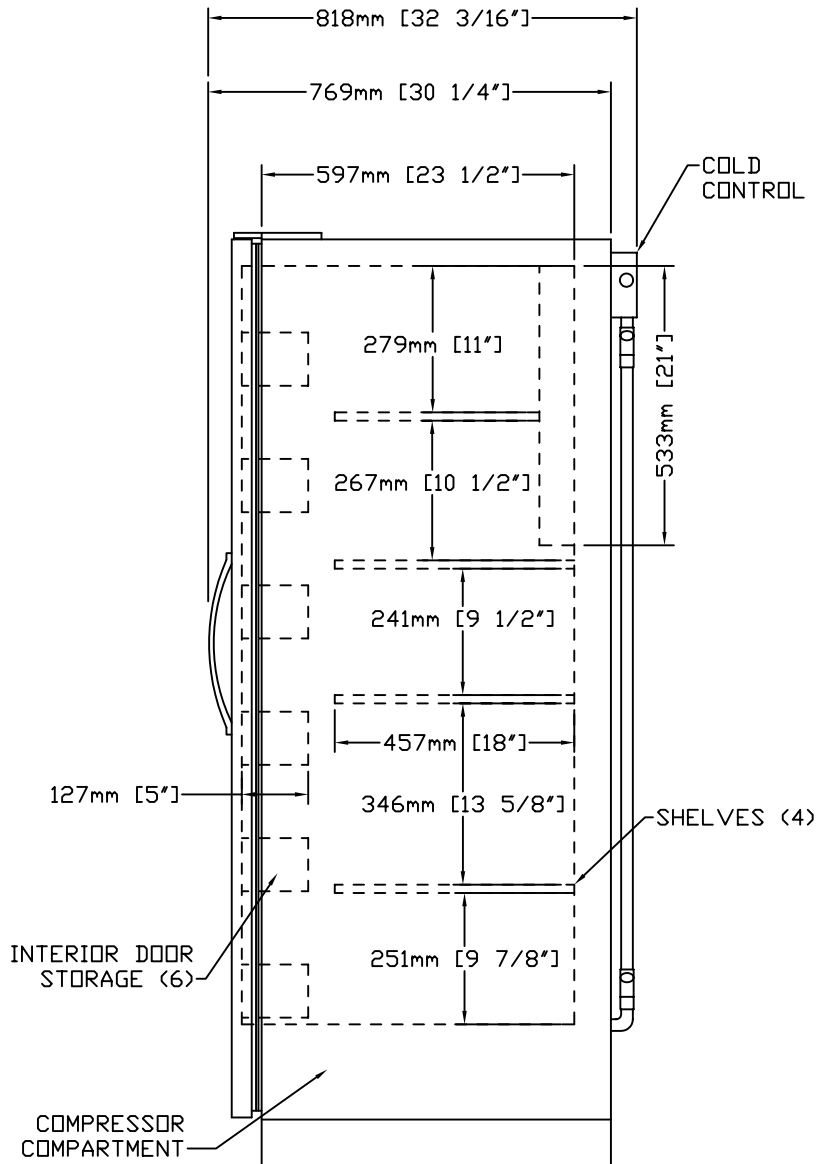

SIDE VIEW

11/2003

REVCO

REVCO
 275 Aiken Road
 Asheville, NC 28804
 TEL. 1-800-252-7100
 TEL. 828-658-2711 FAX 828-658-0363

MODEL RFS214A

GENERAL SPECIFICATIONS

EXTERIOR - WHITE TEXTURED VINYL ON STEEL

WIDTH 813mm (32") DEPTH 818mm (32.2") HEIGHT 1783mm (70.2")

INTERIOR - WHITE TEXTURED VINYL ON STEEL

WIDTH 686mm (27") DEPTH 597mm (23.5") HEIGHT 1448mm (57")

INSULATION - FOAMED-IN-PLACE POLYURETHANE

GASKET - MAGNETIC

DOOR - SOLID, KEY LOCK

SHELVES - (4) ALUMINUM, NON-ADJUSTABLE, (6) BUILT-IN DOOR SHELVES

FEET - (4) LEVELING, FRONT ONLY

CONTROL - (1) THERMOSTATIC, MAY BE SET FOR DESIRED TEMPERATURE

+2°C TO +10°C (36°F TO 50°F) FACTORY SET TO +4°C (39°F)

DEFROST - MANUAL

COMPRESSOR - 1/4 H.P., R134a REFRIGERANT, NOMINAL BTU'S TO ROOM

AMBIENT - 86 WATTS (295 BTU'S/HR)

DECIBEL RATING - 45 dBA

CAPACITY - 586 L (20.7 CU. FT.)

ELECTRICAL DATA - 120/60/1 5 AMPS

SHIPPING WEIGHT - 113 KG (250 LBS)

SHIPPING VOLUME - 2.0 CU. METERS (70 CU. FEET)